

# VOLTAIR





# VOLTAIR

Exceptionally elegant yet reassuringly practical, VOLTAIR is our answer to the need for greater versatility and flexibility in the workspace. Designed and engineered with the ethos of creating a cost-effective workspace for individual and collaborative work, VOLTAIR provides you with a workspace that delivers a supreme work quality at an exceptionally reasonable price.

VOLTAIR workstations are available in Single Desk, a Side-by-Side or Back-to-back cluster. VOLTAIR's flexibility allows for different sizes within the same footprint, giving you a greater range of versatility within its range.





VOLTAIR's privacy screens provide visual and audio privacy. Screens are fixed to the frame or bench as a static barrier, allowing you to isolate your working space for optimal focus.



### Privacy screen finishes

Screens are also available in the following finishes:





VOLTAIR also features a fully developed cable management system. Services are reticulated and concealed by VOLTAIR's Cable Basket, allowing a discrete flow of data between workstations in a cluster.



01

**01 The VOLTAIR Cluster of Four.**

The VOLTAIR workstation offers a variety of configurations, available in Single, Side-by-side and Cluster of Four

**02 Cable Basket**

VOLTAIR offers both single and two tier Cable Basket solutions, reticulating power and data cables efficiently to free the workspace for you.

**03 Power, voice and data outlets**

VOLTAIR power, voice and data outlets are carefully concealed below the desk, decluttering the your workspace.

**04 In-desk power boxes or above desk power rails**

VOLTAIR adaptable power options allow you to conceal power and data cables using its in-desk power box, or externalise them using VOLTAIR'S above desk power rails.

**05 Vertical power management via power poles, power blades or umbilicals**

VOLTAIR provides a variety of power management solutions for ceiling powered workspaces, allowing you to select the solution that best fits you.

**06 Adjustable Glides**

VOLTAIR's Adjustable Glides allow you to level and adjust VOLTAIR to the unique needs of your workspace. A workstation that works for you.

**07 VOLTAIR accessories**

The VOLTAIR series comes with a family of accessories and adjustable add-ons, allowing you to tailor VOLTAIR for your own individual workspace needs.

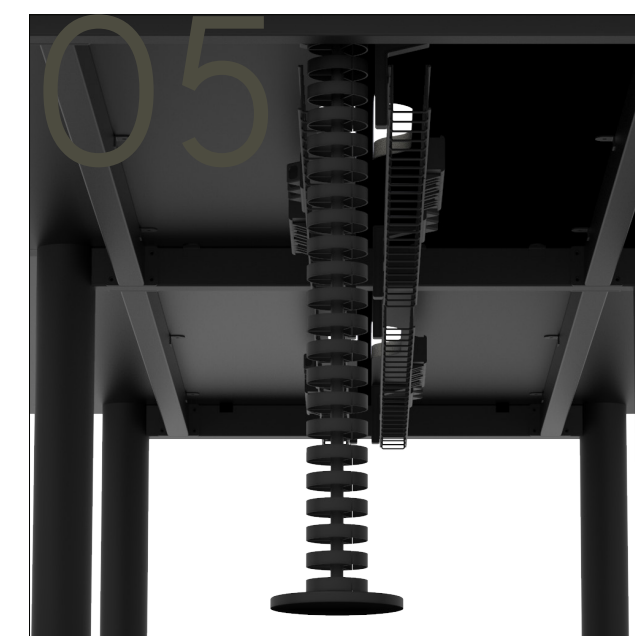

VOLTAIR can be adapted to individual requirements with a combination of document trays, function walls, shelves, monitor arms, CPU cradles and castors





# VOLTAIR

TECHNICAL SPECIFICATIONS

# VOLTAIR

## WORKSTATIONS

VOLTAIR Linear single workstation

### Materials Information

#### 1. Tops

25mm commercial Melamine, Laminate or Veneer worktops. Solid wood or ABS edging.

#### 2. Legs and Frame

VOLTAIR's Legs are all manufactured using powder-coated Steel. Powder-coated Steel legs, come in both white and black variations. Other Colours can be made available as specified.

#### 3. Frame Finishes

VOLTAIR's frames are all manufactured using powder-coated Steel. White or Black powder-coat comes as standard. Other Colours can be made available as specified.

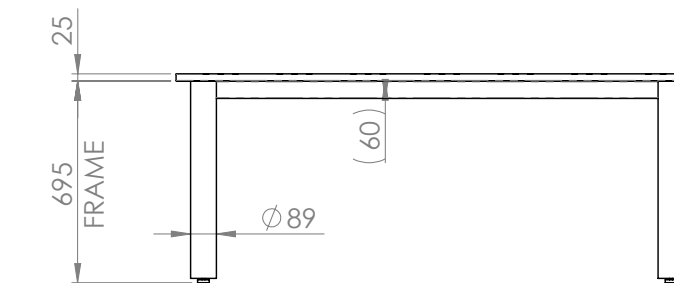
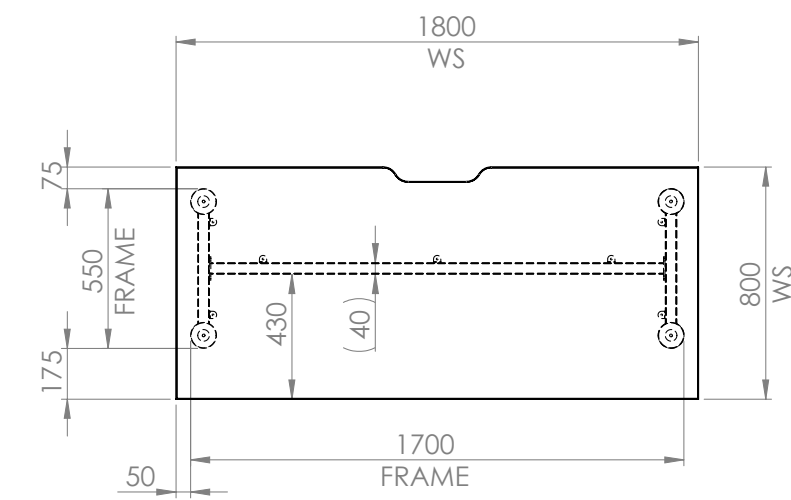

VOLT Linear Side-by-side workstation

### Materials Information

#### 1. Tops

25mm commercial Melamine, Laminate or Veneer worktops. Solid wood or ABS edging.

#### 2. Legs

VOLTAIR's Legs are all manufactured using powder-coated Steel. Powder-coated Steel legs, come in both white and black variations. Other Colours can be made available as specified.

#### 3. Frame Finishes

VOLTAIR's frames are all manufactured using powder-coated Steel. White or Black powder-coat comes as standard. Other Colours can be made available as specified.

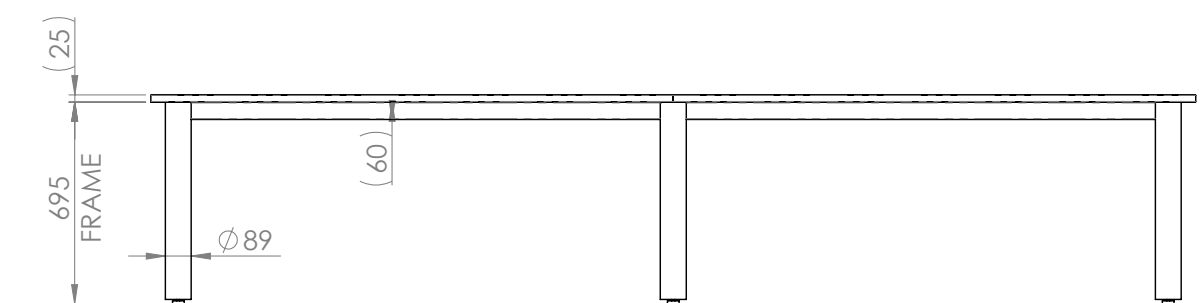
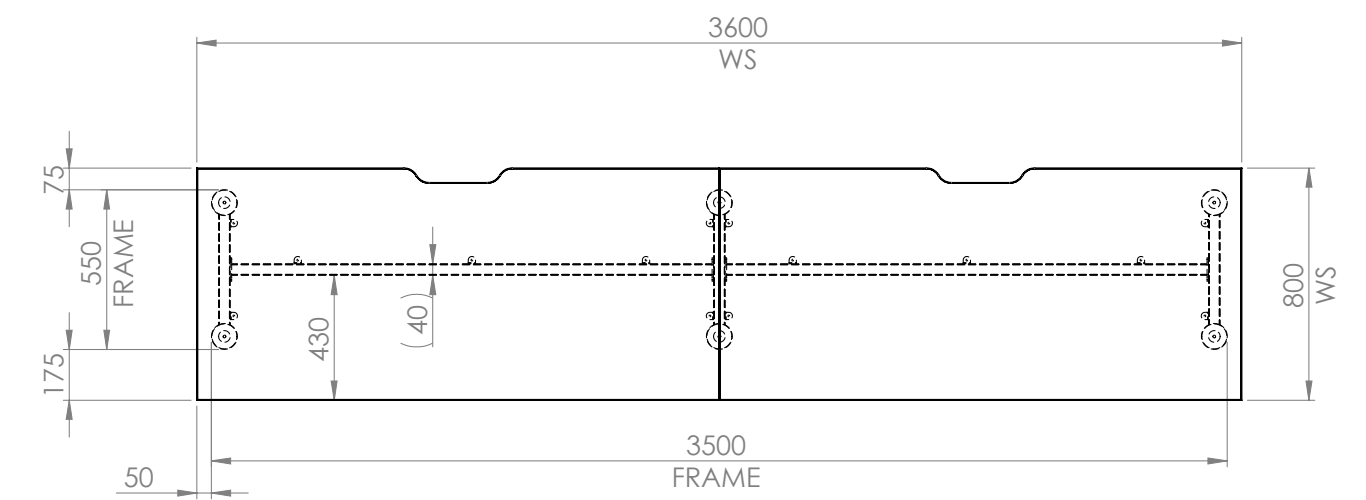

# VOLTAIR

TECHNICAL SPECIFICATIONS

# VOLTAIR

WORKSTATIONS

VOLT Cluster of four workstation

### Materials Information

#### 1. Tops

25mm commercial Melamine, Laminate or Veneer worktops. Solid wood or ABS edging.

#### 2. Legs and Frame

VOLTAIR's Legs are all manufactured using powder-coated Steel. Powder-coated Steel legs, come in both white and black variations. Other Colours can be made available as specified.

#### 3. Frame Finishes

VOLTAIR's frames are all manufactured using powder-coated Steel. White or Black powder-coat comes as standard. Other Colours can be made available as specified.

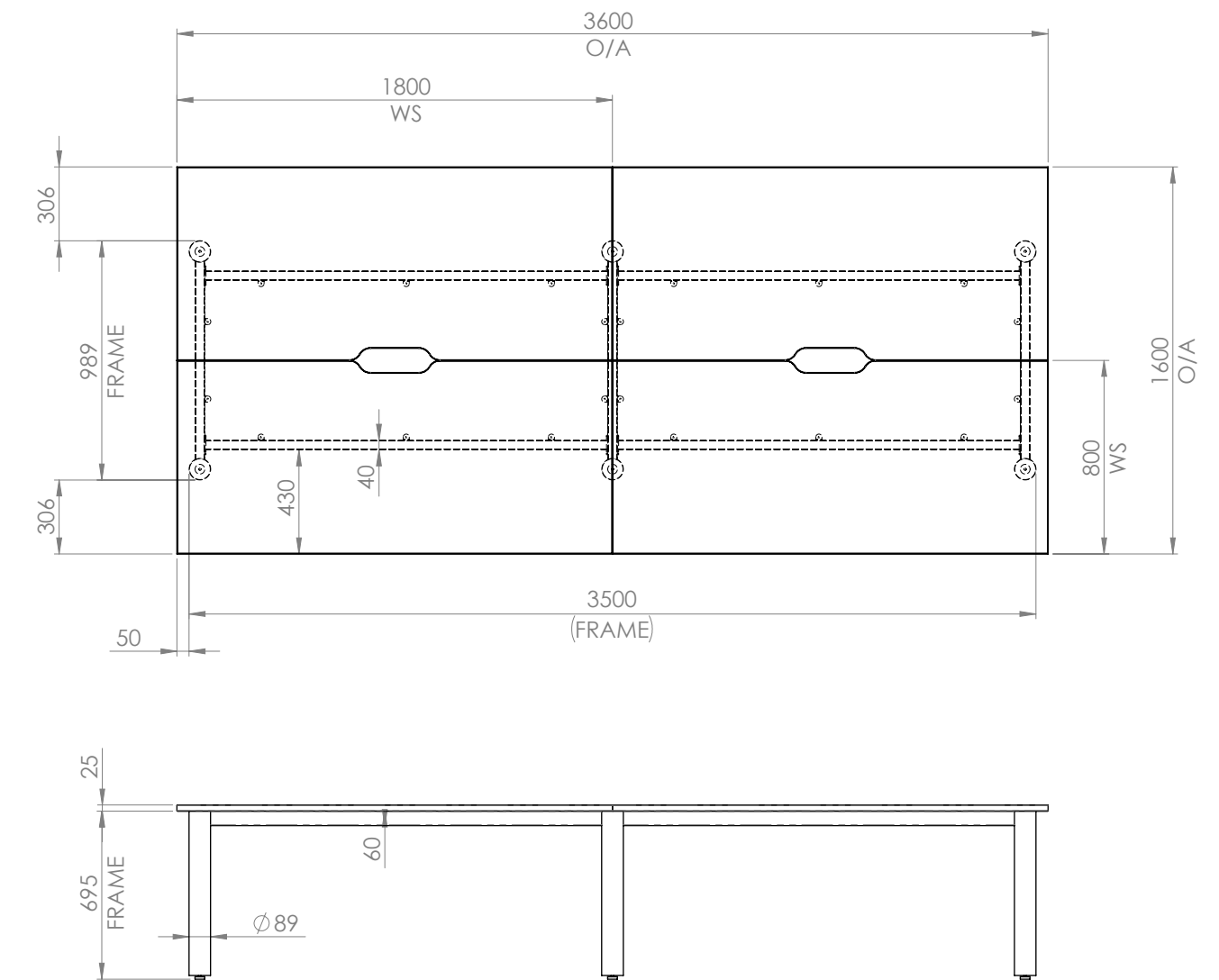



# VOLTAIR

FINISHES SPECIFICATIONS

# VOLTAIR

## FINISHES

Adroit and versatile, VOLTAIR yields the importance of adaptability for your own needs, offering a range of finishes and configurations to suit any office space.

### 1. Tops

25mm commercial Melamine, Laminate or Veneer worktops. Solid wood or ABS edging.



### 2. Legs

VOLTAIR's Legs are all manufactured using powder-coated Steel. Powder-coated Steel legs, come in both white and black variations. Other Colours can be made available as specified.

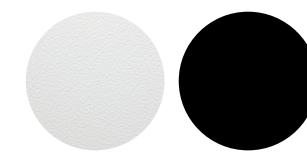

### 3. Frame Finishes

VOLTAIR's frames are all manufactured using powder-coated Steel. White or Black powder-coat comes as standard. Other Colours can be made available as specified.

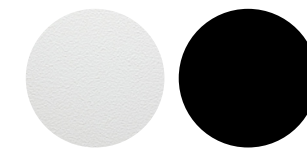



## VOLTAIR

EXCEPTIONALLY ELEGANT YET REASSURINGLY PRACTICAL. VOLTAIR IS OUR ANSWER TO THE NEED FOR GREATER VERSATILITY AND FLEXIBILITY IN THE WORKSPACE. DESIGNED AND ENGINEERED WITH THE ETHOS OF CREATING A COST EFFECTIVE WORKSPACE FOR INDIVIDUAL AND COLLABORATIVE WORK. VOLTAIR PROVIDES YOU WITH A WORKSPACE THAT DELIVERS A SUPREME WORK QUALITY AT AN EXCEPTIONALLY REASONABLE PRICE.

### SUSTAINABILITY POLICY

WE BELIEVE A TRULY SUSTAINABLE BUSINESS SHOULD EMBRACE ENVIRONMENTAL, SOCIAL, AND CULTURAL VALUES. OUR PHILOSOPHY MEANS THAT WE EXAMINE EVERYTHING WE DO TO MINIMISE OUR IMPACT ON THE ENVIRONMENT STARTING WITH THE DESIGN OF OUR PRODUCTS, THE SELECTION OF MATERIALS, MANUFACTURING, ASSEMBLY AND INSTALLATION, PRACTICES IN OUR OFFICES AND ACCEPTING THE RESPONSIBILITY FOR OUR PRODUCTS' LIFE CYCLES.

### ENVIRONMENTAL POLICY

RJ OFFICE HAS BEEN ON A SUSTAINABILITY JOURNEY SINCE 2008, ACHIEVING ENVIRONMENTAL PRODUCT CERTIFICATION AND IN 2009, ATTAINING ISO14001 EMS CERTIFICATION. AS PART OF OUR ENVIRONMENTAL MANAGEMENT SYSTEM, WE ARE COMMITTED TO CONTINUALLY IMPROVING OUR ENVIRONMENTAL PRACTICES TO ENSURE THAT WE MAINTAIN A BALANCE BETWEEN THE ENVIRONMENT AND OUR BUSINESS.

### PRODUCT STEWARDSHIP POLICY

OUR PRODUCT STEWARDSHIP POLICY FOR RJ PRODUCTS PROVIDES USERS WITH A NUMBER OF OPTIONS.

WE ENCOURAGE OUR CUSTOMERS TO CONTACT US ABOUT RETURN OF OUR PRODUCTS. IF THE PRODUCTS CANNOT BE REUSED OR REFURBISHED, RJ OFFICE COMMITS TO TAKE THE PRODUCTS BACK, AT AN AGREED COST, AND ENSURE THAT THEY ARE DISASSEMBLED AND THE COMPONENTS ARE RECYCLED OR WHERE APPROPRIATE DISPOSED OF RESPONSIBLY.

PHONE: (02) 9299 9090

RJ OFFICE P/L  
COPYRIGHT 2020  
ALL RIGHTS RESERVED

SHOWROOM  
25 SHELLEY ST  
KING STREET WHARF  
SYDNEY NSW 2000  
T: +61 2 9299 9090

LOGISTICS  
BUILDING 2  
112 LILYFIELD ROAD  
LILYFIELD NSW 2040  
T: +61 2 9818 8788

[info@rj.com.au](mailto:info@rj.com.au)  
[rj.com.au](http://rj.com.au)

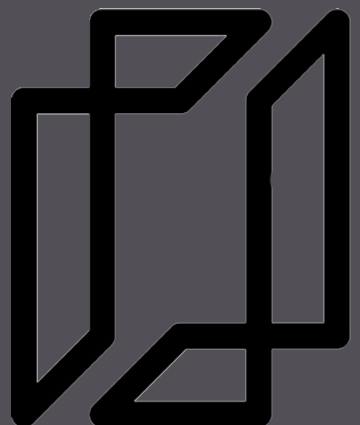



**IMAGINE, INNOVATE, CREATE.**

[WWW.RJ.COM.AU](http://WWW.RJ.COM.AU)