

# PODS





# PODS

Increasing flexibility and productivity in the modern office space is crucial. Introducing PODS, a compact single person workstation for tasks requiring privacy from environmental influences common in open workspaces. PODS create the opportunity to deliver new ways of working, both collaboratively and exclusively.

PODS is designed with the intention of creating new working opportunities, drawing in a healthy balance of collaborative and focused work. Due to its creative geometric construction, PODS provides the versatility and portability for those who don't want their office space fixed, adhering to the flexible nature of modern office floor plates.



PODS' Acoustic screens provide visual and audio privacy. Its privacy screens are free standing elements, available in a variety of materials to suit your individual needs.

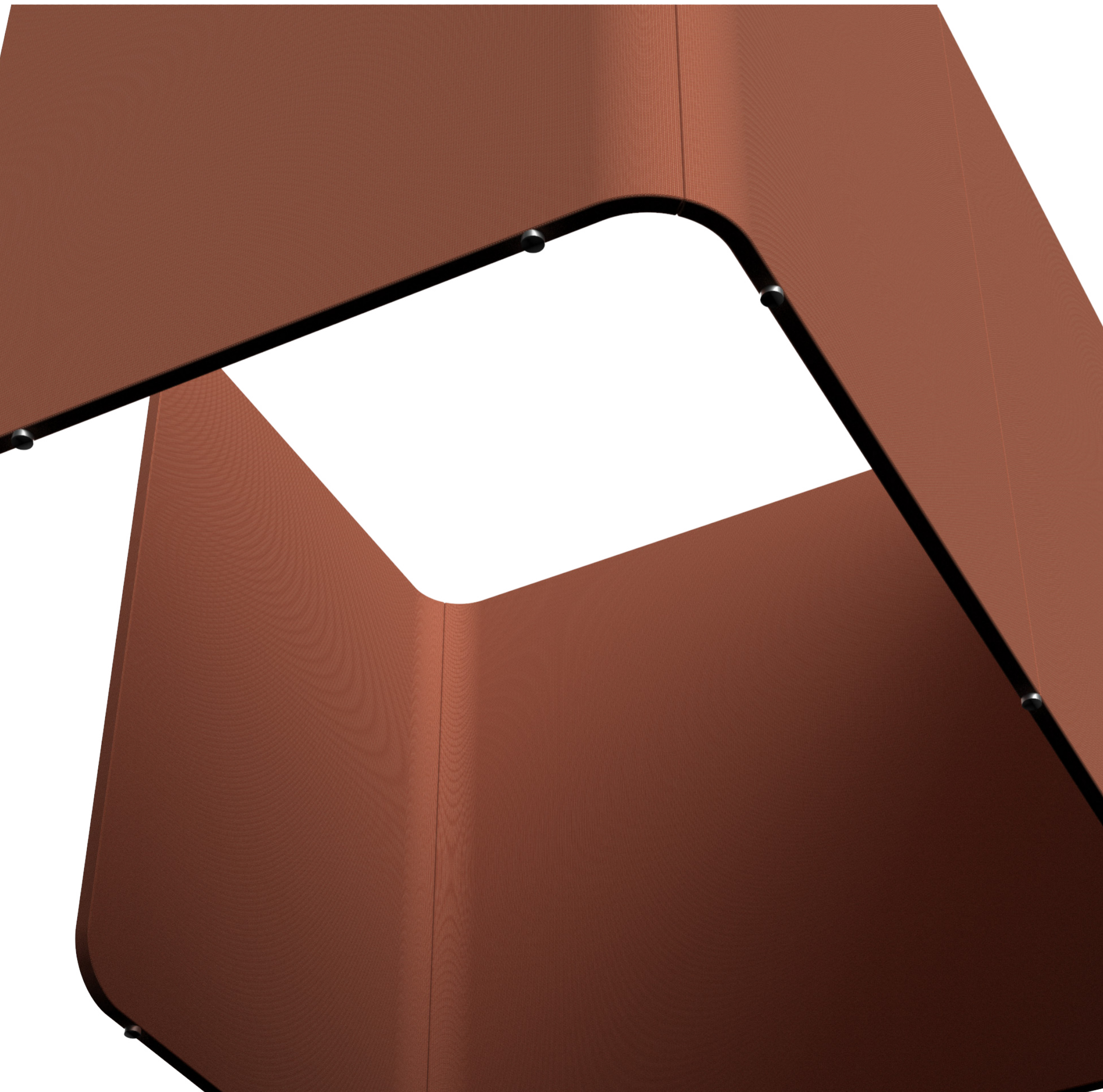

#### Acoustic screen finishes

Screens are available in a variety of fabrics.

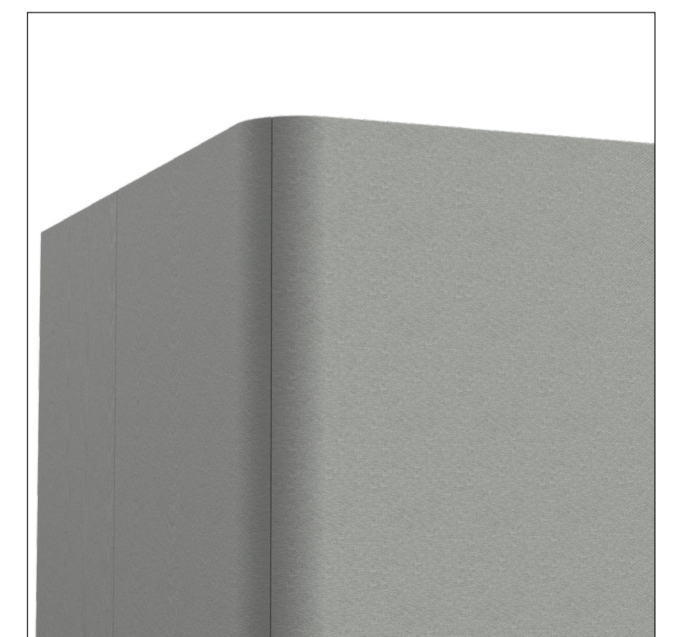
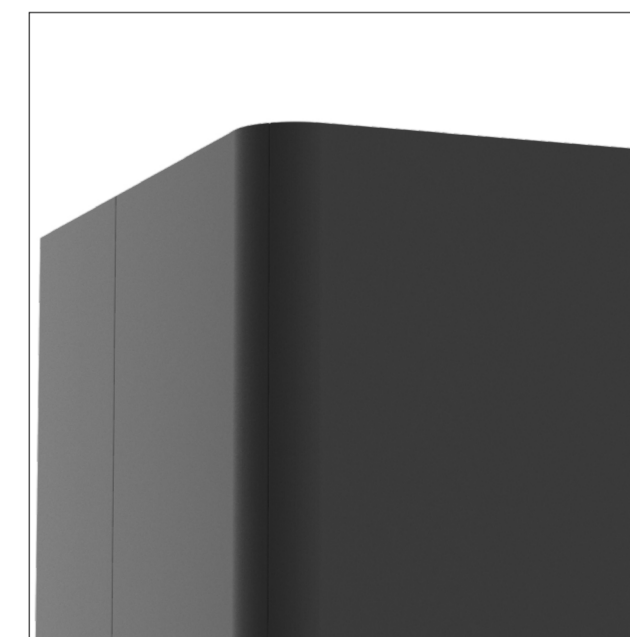
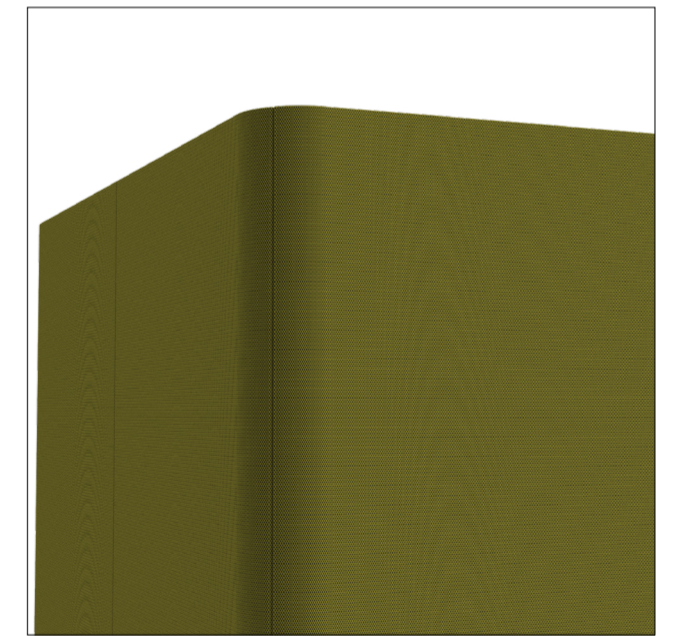
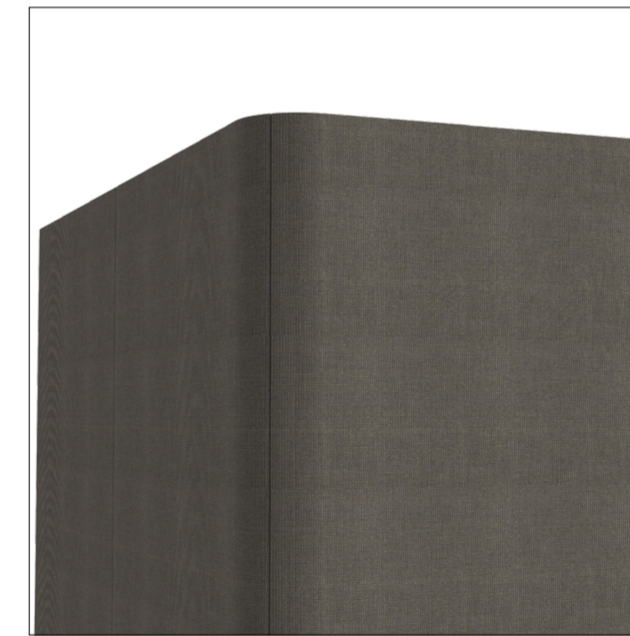
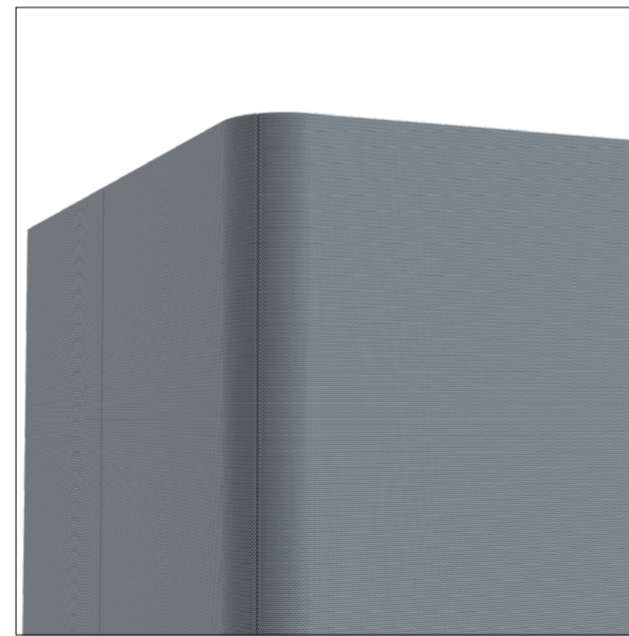

PODS' internally routed cable management system facilitates power and data solutions, carefully reticulating cables discretely below the work surface.

**01 The PODS Dual Workstation.**

Due to its versatile nature, The PODS workstation can be configured in a variety of configurations, or placed simply by itself for a singular workstation.

**02 Single or Two Tier cable trays**

PODS offers both single and two tier cable tray solutions, reticulating power and data cables efficiently to free the workspace for you.

**03 Power, voice and data outlets**

PODS' power, voice and data outlets are carefully concealed below the desk, decluttering the workspace.

**04 In-desk power boxes or above desk power rails**

PODS' adaptable power options allow you to conceal power and data cables using its in-desk power box, or externalise them using above desk power rails.

**05 Vertical power management from ceiling via power poles, power blades or umbilicals**

PODS' provides a variety of power management solutions for ceiling powered workspaces, allowing you to select the solution that best fits you.

**06 Plastic/Felt feet**

PODS' feet can be selected in either plastic or felt versions.

**07 PODs' table tops**

PODS' desks come in 25mm melamine, laminate or veneer, providing various configurations for your individual working space needs.



01

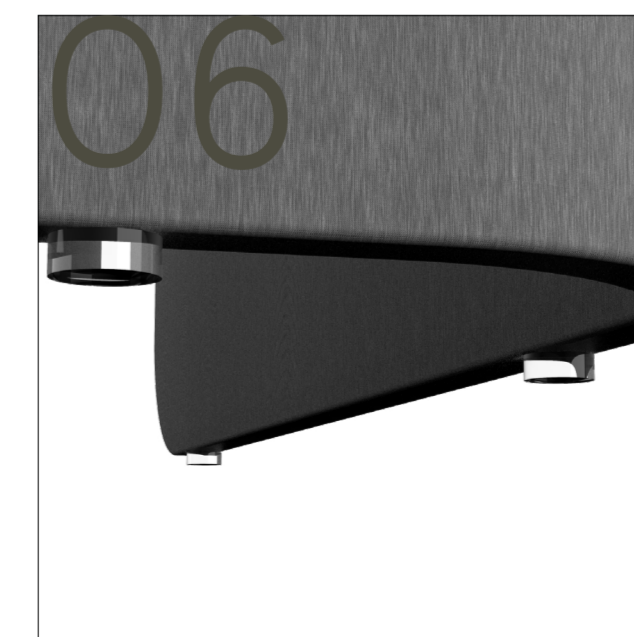
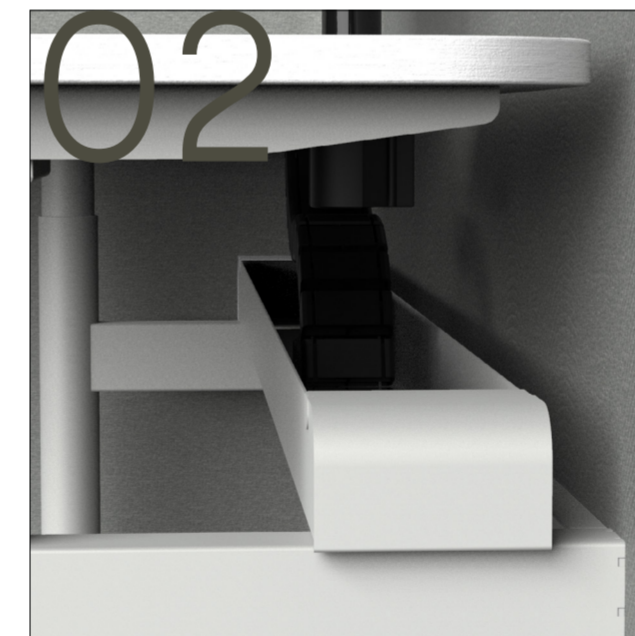

The creative geomteric design of PODS  
allows you to nestle and tessellate  
workstations to maximise your available  
space.



# PODS

## WORKSTATIONS

PODS private side-by-side workstation

### Materials Information

#### 1. Screens

Screens are available in a variety of fabrics. Enquire with an RJ representative to discuss your options.

#### 2. Legs and Frame

PODS' Legs are all manufactured using powder-coated Aluminium. Powder-coated Aluminium legs, come in both white and black variations. Other Colours as part of the Dulux Powder-coat range can be specified.

#### 3. Frame Finishes

PODS' frames are all manufactured using powder-coated Aluminium. White or Black powder-coat comes as standard. Other Colours as part of the Dulux Powder-coat range can be specified.

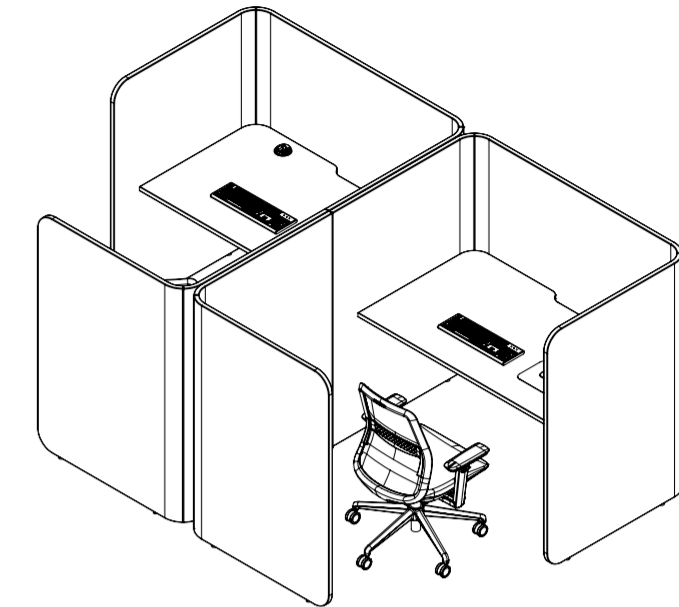
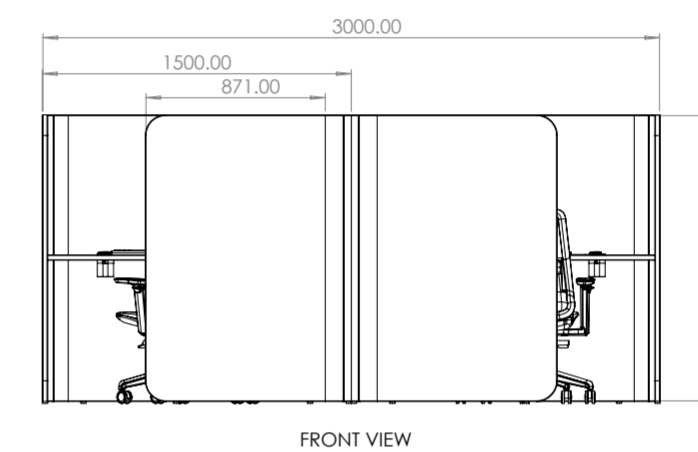
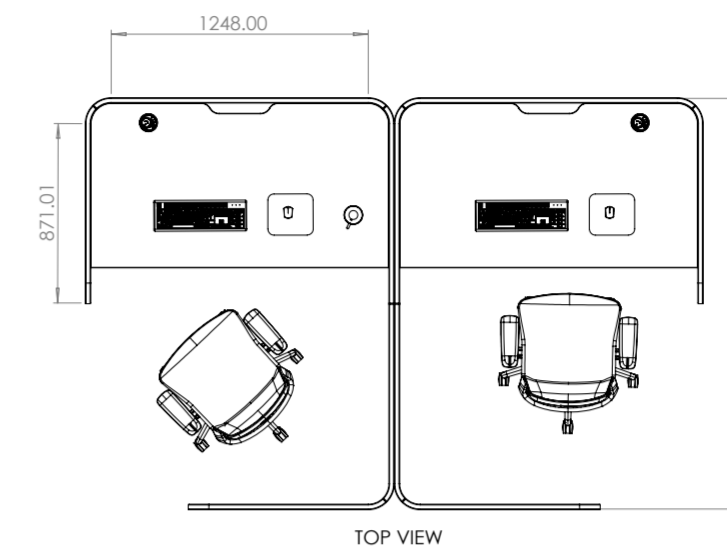

PODS collaborative side-by-side workstation

### Materials Information

#### 1. Screens

Screens are available in a variety of fabrics. Enquire with an RJ representative to discuss your options.

#### 2. Legs

PODS' Legs are all manufactured using powder-coated Aluminium. Powder-coated Aluminium legs, come in both white and black variations. Other Colours as part of the Dulux Powder-coat range can be specified.

#### 3. Frame Finishes

PODS' frames are all manufactured using powder-coated Aluminium. White or Black powder-coat comes as standard. Other Colours as part of the Dulux Powder-coat range can be specified.

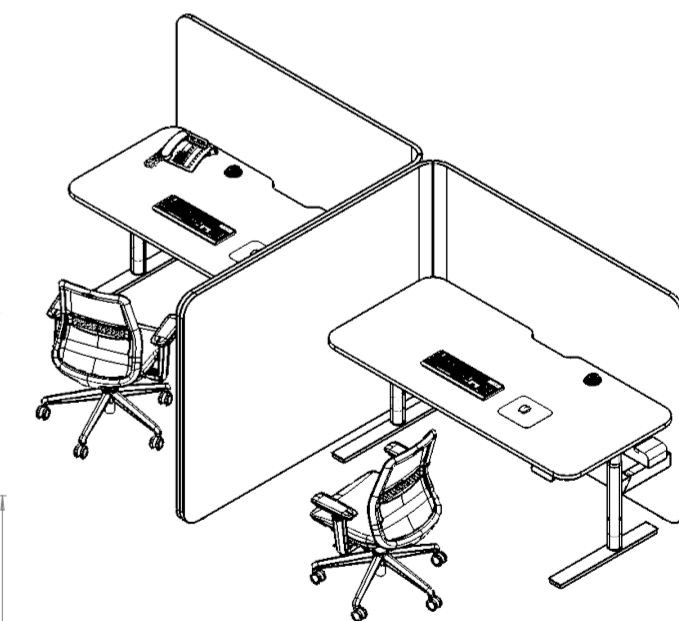
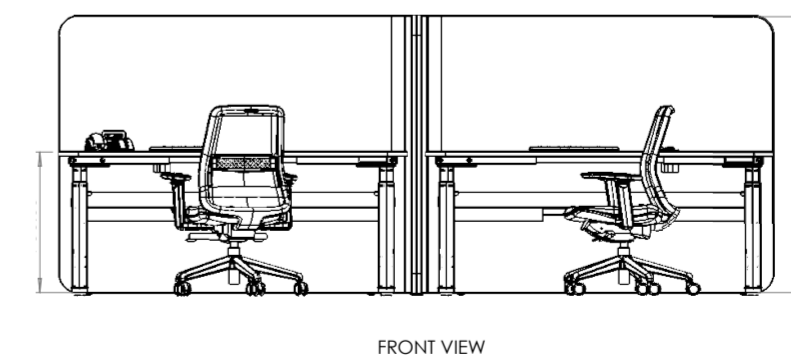
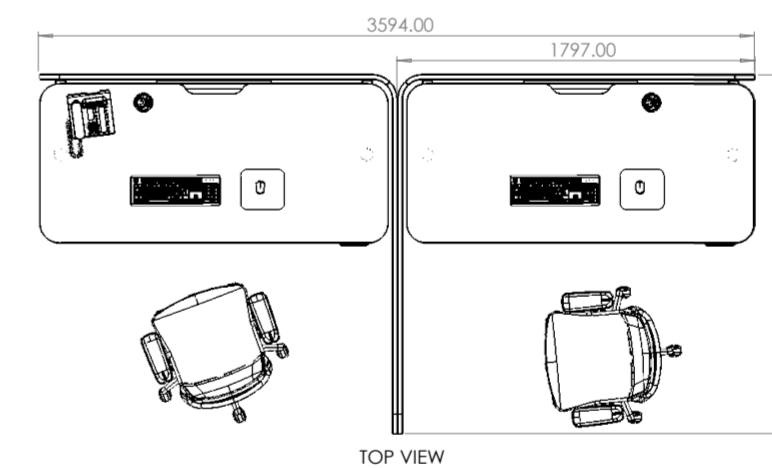

# PODS

FINISHES SPECIFICATIONS

# PODS

## FINISHES

Clever and agile, PODS yields the importance of adaptability for your own needs, offering a range of finishes and configurations to suit any office space.

### 1. Screens

Screens are available in a variety of fabrics. Enquire with an RJ representative to discuss your options.

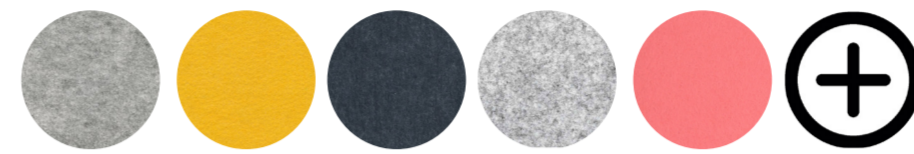

### 2. Leg finishes

PODS' Legs are all manufactured using powder-coated Aluminium. Powder-coated Aluminium legs, come in both white and black variations. Other Colours as part of the Dulux Powder-coat range can be specified.

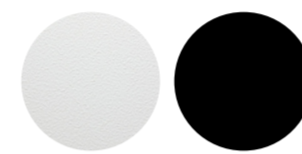

### 3. Frame finishes

PODS' frames are all manufactured using powder-coated Aluminium. White or Black powder-coat comes as standard. Other Colours as part of the Dulux Powder-coat range can be specified.

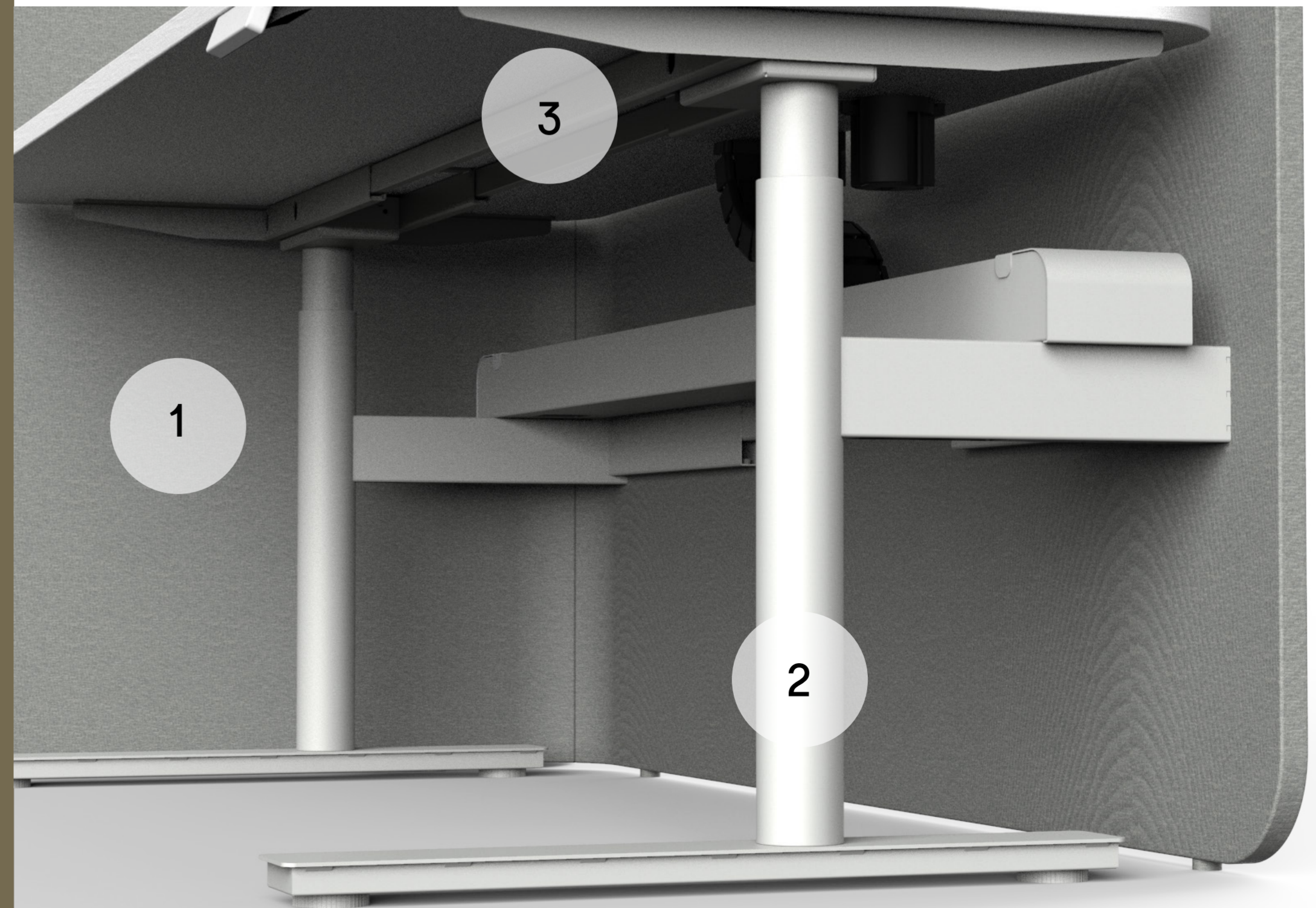
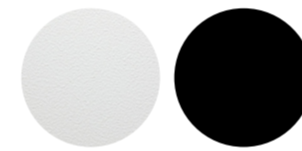



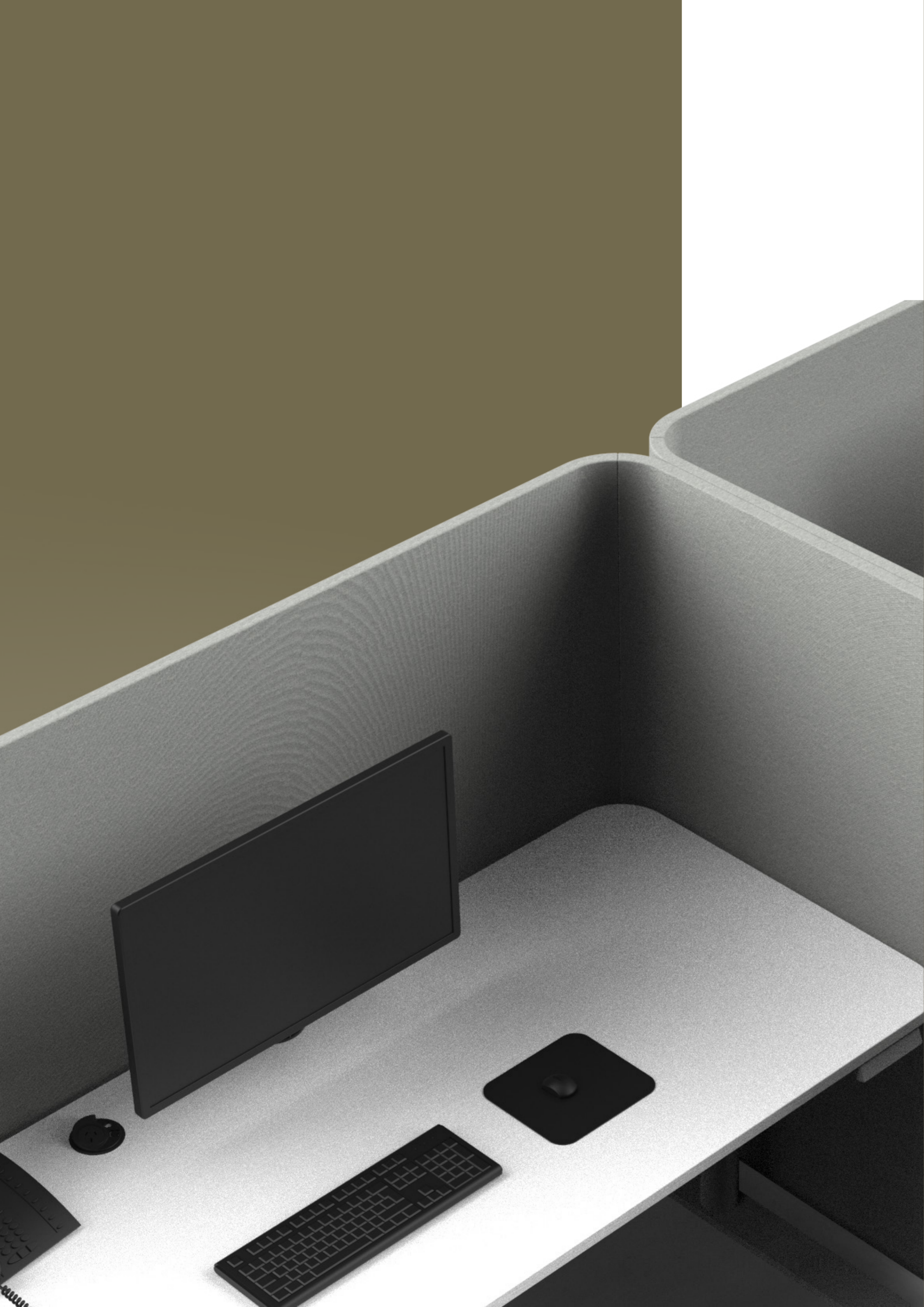

## PODS

INCREASING FLEXIBILITY AND PRODUCTIVITY IN THE MODERN OFFICE SPACE IS CRUCIAL. INTRODUCING PODS, A COMPACT SINGLE PERSON WORKSTATION FOR TASKS REQUIRING PRIVACY FROM ENVIRONMENTAL INFLUENCES COMMON IN OPEN WORKSPACES. PODS CREATE THE OPPORTUNITY TO DELIVER NEW WAYS OF WORKING, BOTH COLLABORATIVELY AND EXCLUSIVELY.

## SUSTAINABILITY POLICY

WE BELIEVE A TRULY SUSTAINABLE BUSINESS SHOULD EMBRACE ENVIRONMENTAL, SOCIAL AND CULTURAL VALUES. OUR PHILOSOPHY MEANS THAT WE EXAMINE EVERYTHING WE DO TO MINIMISE OUR IMPACT ON THE ENVIRONMENT STARTING WITH THE DESIGN OF OUR PRODUCTS, THE SELECTION OF MATERIALS, MANUFACTURING, ASSEMBLY AND INSTALLATION, PRACTICES IN OUR OFFICES AND ACCEPTING THE RESPONSIBILITY FOR OUR PRODUCTS' LIFE CYCLES.

## ENVIRONMENTAL POLICY

RJ OFFICE HAS BEEN ON A SUSTAINABILITY JOURNEY SINCE 2008, ACHIEVING ENVIRONMENTAL PRODUCT CERTIFICATION AND IN 2009, ATTAINING ISO14001 EMS CERTIFICATION. AS PART OF OUR ENVIRONMENTAL MANAGEMENT SYSTEM, WE ARE COMMITTED TO CONTINUALLY IMPROVING OUR ENVIRONMENTAL PRACTICES TO ENSURE THAT WE MAINTAIN A BALANCE BETWEEN THE ENVIRONMENT AND OUR BUSINESS.

## PRODUCT STEWARDSHIP POLICY

OUR PRODUCT STEWARDSHIP POLICY FOR RJ PRODUCTS PROVIDES USERS WITH A NUMBER OF OPTIONS.

WE ENCOURAGE OUR CUSTOMERS TO CONTACT US ABOUT RETURN OF OUR PRODUCTS. IF THE PRODUCTS CANNOT BE REUSED OR REFURBISHED, RJ OFFICE COMMITS TO TAKE THE PRODUCTS BACK, AT AN AGREED COST AND ENSURE THAT THEY ARE DISASSEMBLED AND THE COMPONENTS ARE RECYCLED OR WHERE APPROPRIATE DISPOSED OF RESPONSIBLY.

PHONE: (02) 9299 9090

RJ OFFICE P/L  
COPYRIGHT 2020  
ALL RIGHTS RESERVED

## SHOWROOM

25 SHELLEY ST  
KING STREET WHARF  
SYDNEY NSW 2000  
T: +61 2 9299 9090

## LOGISTICS

BUILDING 2  
112 LILYFIELD ROAD  
LILYFIELD NSW 2040  
T: +61 2 9818 8788

[info@rj.com.au](mailto:info@rj.com.au)  
[rj.com.au](http://rj.com.au)



**IMAGINE, INNOVATE, CREATE.**

[WWW.RJ.COM.AU](http://WWW.RJ.COM.AU)